



Enzymatic activity measurements in *Streptococcus thermophilus*

Department of Food Science and Microbiology (Di.S.T.A.M),
University of Milan - Italy

CONTEXT

Streptococcus thermophilus is a major component of dairy starter cultures used for the manufacture of yoghurt and cheese.

In this study, β -galactosidase and lactate dehydrogenase activities were measured in *Streptococcus thermophilus* cells to evaluate the effect of carbon dioxide availability on the homolactic fermentation process¹.

MATERIAL

- Precellys[®]24
- Precellys[®] kit: 03961-1-004 (glass beads 0.5 mm)
- Sample: Concentrated *S. thermophilus* cells washed
- Buffer: 50mM tris/HCl buffer, pH7.

PROTOCOL

- Precellys[®]24: 6800 rpm, 3 x 30 sec (30 sec break) in cold room or using Cryolys cooling option.
- Centrifugation: 15.000 xg, 10 min, +4°C.
- Analysis: Protein content within total cell extract by Bradford method / β -galactosidase and lactate dehydrogenase activities measured spectrophotometrically¹.

1) S.Arioli et al., Microbiology 155 (2009), 1953-1965; DOI 10.1099/mic.0.024737-0

RESULTS

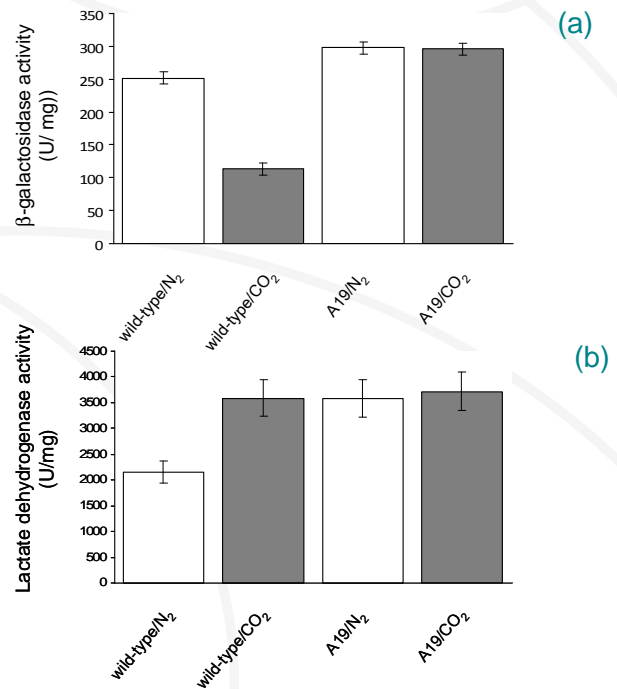

Figure 1: β -galactosidase (a) and lactate dehydrogenase (b) activities of *S. thermophilus* wild-type cells (white bars) and A19(Δ pcc; Δ carB) mutant cells (grey bars) grown in enriched CO₂ or N₂ atmosphere.

Our results originally show a direct correlation between the distribution of the HPr phosphorylated isoforms and the measured level of β -galactosidase and lactate dehydrogenase activities (Fig. 1) and its relevance in milk acidification process.

CONCLUSION

Comparing to the former classical method of bacterial cell disruption, the use of **Precellys[®]24** allows a perfect homogenization of the samples. Precellys[®]24 is easy to use, simple, efficient and much faster than the former method. The small dimension of Precellys[®]24 allow its location in a cold room thus preserving the activities of the overall enzymatic cell machinery.

Precellys[®]24 brings us efficiency, modernity, homogeneity in the results and time-saving.

For more details, please contact precellys@bertin.fr

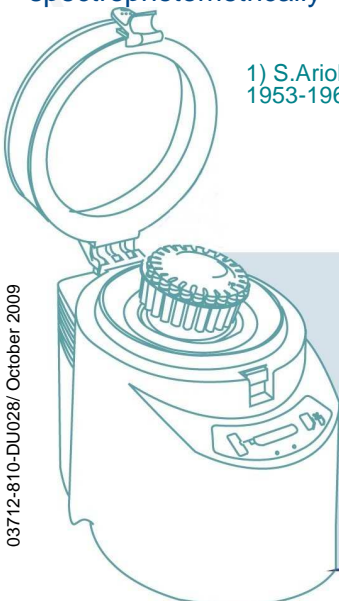

Problem



Solution

